



HTD-24B LED module light source

Description of products:

HTD-24B Constitute by:

ABS shell, PC light lens, 1.5mm MCPCB and Pure copper lines, big LED chip 3030SMD.

LED beam angle can be choose:

60°×20° Through lens finished---Main for use to side shine back light in advertising light box.

This new products than rigid strip more flexibility, the distance between light and light is easy to grasp, can be single LED to use, not need three LEDs.

HTD-24B Working voltage is DC12V, IP65 waterproof level. Warranty is 1 years, power is 1.5W/PCS, when we computing power should retain 20% of the allowance. Up to 20pcs HTD-24B a string to use in one parallel.



HTD-24B (mm)

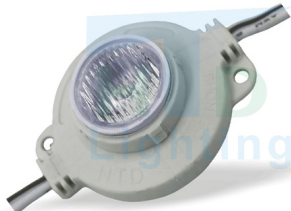

*HTD-24B 20°×60° 1.8W module

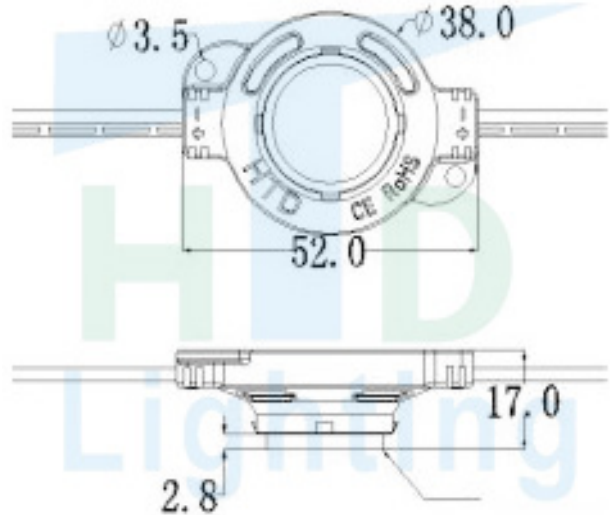

Photometric characteristics & Main material:

Item No.	CCT	LED quantity	luminous flux (LM)	CRI	Light Chip	PCB type	Insulation component
HTD-24B	7000K	1	>190	>75	3030SMD	MCPCB	ABS

HTD-24B LED module & pixel Dual purpose light source parameters:

Item	Parameters	Units
Working voltage	DC12	CCV
Working power	1.5	W
Working temperature	-40~60	°C
IP grade	IP65	*
Optional light color	Warm white/Pure white/Cool white	
Beam Angle	60°×20°	
Light Source Lifespan	≥50000	hrs
Dimensions	∅ 51mm*17mm	Hole:25mm
Net Weight	0.024	Kg



HTD-24B LED module light source

Connection mode (see below)

*LED module/Pixel light/Strip light Single color wiring diagram

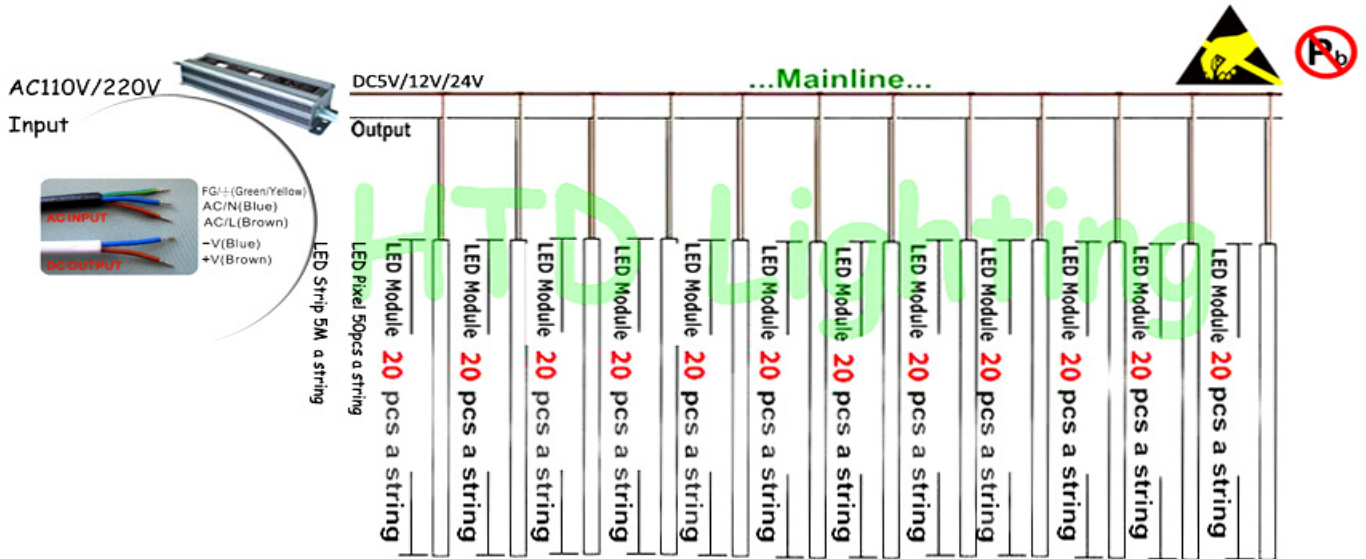

*This product the most can tandem connection 20pcs module/50pcs pixel/5M strip, Prohibited beyond tandem connection. The thickness of power should according to actual possible present maximum current, the power of products, wiring length (suggest not exceeding 6M) and low voltage transmission line voltage drop. In measuring power use number of circumstances, should retain 20% of the allowance.

*(Important) Ensure that both ends connect power, achieve the best use effect. The module MAX 40pcs/string, Pixel MAX 100pcs/string, Strip MAX 10M/String.

A/.DC12V transformer connect 220V/110V AC voltage;

B/.And then,HTD-24B connection DC12V output transformer(± to ± wire).

Package

Every 20pcs per string, 5 strings in an inner package, 1200pcs per carton box.

Carton size: 48cm*48cm*28cm.

Net Weight: 24g/pcs; 30kg/carton.

*LED Module/Pixel/Point light source-Package diagram



Shenzhen HongTai world lighting Co.,LTD

ADD: No.57 building B Third Floor, Tangkeng industrial zone, Baoan Shiyan Shenzhe, GD China.

Tell: +86 755-23002430/23002431

Fax: +86 755-23001713

Official Website: www.szhtdled.com

Company E-mail: szhtdled@szhtdled.com



PS: Save a tree. Kindly don't print this document unless it's really necessary.